

Write your name here

Surname

MODEL ANSWERS

Other names

Pearson Edexcel

Centre Number

Candidate Number

Level 1/Level 2 GCSE (9-1)

Mathematics

Paper 1 (Non-Calculator)

Higher Tier

Thursday 2 November 2017 – Morning

Time: 1 hour 30 minutes

Paper Reference

1MA1/1H

You must have: Ruler graduated in centimetres and millimetres, protractor, pair of compasses, pen, HB pencil, eraser. Tracing paper may be used.

Total Marks

Instructions

- Use **black** ink or ball-point pen.
- **Fill in the boxes** at the top of this page with your name, centre number and candidate number.
- Answer **all** questions.
- Answer the questions in the spaces provided – *there may be more space than you need.*
- You must **show all your working**.
- Diagrams are **NOT** accurately drawn, unless otherwise indicated.
- **Calculators may not be used.**



Information

- The total mark for this paper is 80
- The marks for **each** question are shown in brackets – *use this as a guide as to how much time to spend on each question.*

Advice

- Read each question carefully before you start to answer it.
- Keep an eye on the time.
- Try to answer every question.
- Check your answers if you have time at the end.

Turn over ►

P49308A

©2017 Pearson Education Ltd.

6/6/6/7/2/



P 4 9 3 0 8 A 0 1 2 0



Pearson

Answer ALL questions.

Write your answers in the spaces provided.

You must write down all the stages in your working.

- 1 Write 36 as a product of its prime factors.

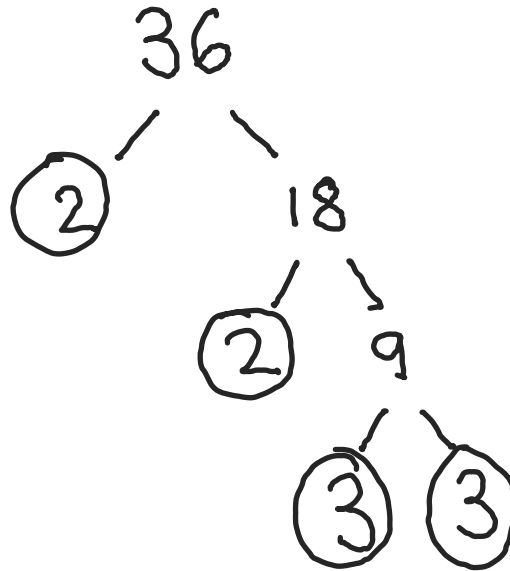

$$2 \times 2 \times 3 \times 3$$

$$2^2 \times 3^2$$

(Total for Question 1 is 2 marks)

DO NOT WRITE IN THIS AREA

DO NOT WRITE IN THIS AREA

DO NOT WRITE IN THIS AREA



- 2 Kiaria is 7 years older than Jay. 1
 Martha is twice as old as Kiaria. 2
 The sum of their three ages is 77 3

Find the ratio of Jay's age to Kiaria's age to Martha's age.

$$\textcircled{1} \quad K = J + 7 \quad \therefore J = K - 7$$

$$\textcircled{2} \quad M = 2K$$

$$\textcircled{3} \quad K + M + J = 77$$

$$K + 2K + K - 7 = 77$$

$$4K - 7 = 77$$

$$4K = 84$$

$$K = 21$$

$$M = 2 \times 21 = 42$$

$$J = 21 - 7 = 14$$

$$J : K : M \\ 14 : 21 : 42$$

(Total for Question 2 is 4 marks)



3

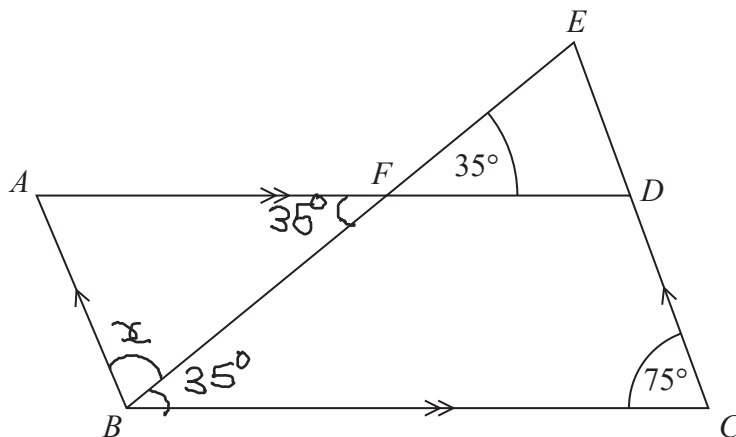

$ABCD$ is a parallelogram.

EDC is a straight line.

F is the point on AD so that BFE is a straight line.

Angle $EFD = 35^\circ$

Angle $DCB = 75^\circ$

Show that angle $ABF = 70^\circ$

Give a reason for each stage of your working.

$$\angle AFB = 35^\circ \quad (\text{opposite angles are equal})$$

$$\angle FBC = 35^\circ \quad (\text{alternate angles (z) are equal})$$

$$\angle ABC = 105^\circ \quad (\text{cointerior angles add to } 180)$$

$$\angle ABF = \angle ABC - \angle FBC$$

$$\therefore \angle ABF = 105 - 35$$

$$\therefore \angle ABF = 70$$

(Total for Question 3 is 4 marks)

DO NOT WRITE IN THIS AREA

DO NOT WRITE IN THIS AREA

DO NOT WRITE IN THIS AREA

4



P 4 9 3 0 8 A 0 4 2 0

- 4 The diagram shows a logo made from three circles.

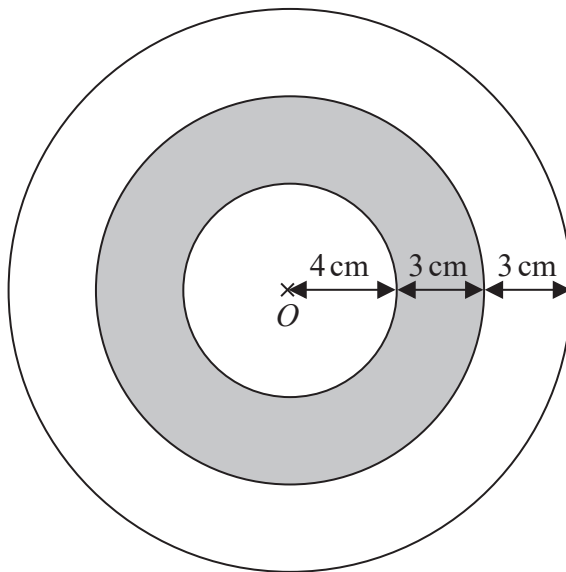

Each circle has centre O .

Daisy says that exactly $\frac{1}{3}$ of the logo is shaded.

Is Daisy correct?

You must show all your working.

Area of the whole circle:

$$r = 4 + 3 + 3 = 10 \text{ cm}$$

$$\text{area} = \pi \times 10^2$$

$$= 100\pi \text{ cm}^2$$

Area of circle with r (4+3):

$$r = 4 + 3 = 7 \text{ cm}$$

$$\text{area} = \pi \times 7^2$$

$$= 49\pi \text{ cm}^2$$

Area of circle with $r = 4 \text{ cm}$:

$$\text{area} = \pi \times 4^2$$

$$= 16\pi \text{ cm}^2$$

$$\text{Shaded region} = 49\pi - 16\pi = 33\pi \text{ cm}^2$$

$$\text{fraction} = \frac{33\pi}{100\pi} = \frac{33}{100} \neq \frac{1}{3} \text{ Daisy is incorrect. } \therefore$$

(Total for Question 4 is 4 marks)



5 The table shows information about the weekly earnings of 20 people who work in a shop.

| Weekly earnings (£ x) | Frequency | M_p | $M_p \times F$ |
|--------------------------|-----------|-------|----------------|
| $150 < x \leq 250$ | 1 | 200 | 200 |
| $250 < x \leq 350$ | 11 | 300 | 3300 |
| $350 < x \leq 450$ | 5 | 400 | 2000 |
| $450 < x \leq 550$ | 0 | 500 | 0 |
| $550 < x \leq 650$ | 3 | 600 | 1800 |
| Total | | 20 | 7300 |

(a) Work out an estimate for the mean of the weekly earnings.

$$\text{Mean} = \frac{\sum f x \checkmark^{mp}}{\sum f} = \frac{7300}{20}$$

$$= \frac{365}{1} = 365$$

£ 365
(3)

Nadiya says,

“The mean may **not** be the best average to use to represent this information.”

(b) Do you agree with Nadiya?
You must justify your answer.

Yes, because the 3 values in $550 < x \leq 650$ group are far from the modal group, meaning they may be outliers, skewing the mean.
(1)

(Total for Question 5 is 4 marks)

DO NOT WRITE IN THIS AREA

DO NOT WRITE IN THIS AREA

DO NOT WRITE IN THIS AREA



6 Here is a rectangle.

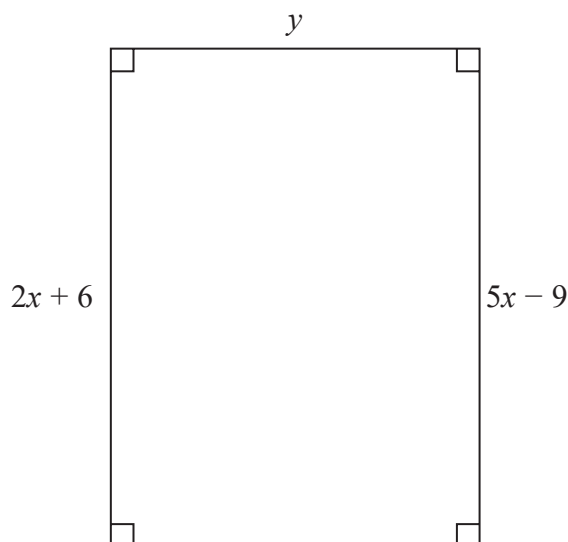

All measurements are in centimetres.

The area of the rectangle is 48 cm^2 .

Show that $y = 3$

$$\begin{array}{r}
 2x + 6 = 5x - 9 \\
 -2x \quad -2x \\
 \hline
 6 = 3x - 9 \\
 +9 \quad +9 \\
 \hline
 15 = 3x \\
 \div 3 \quad \div 3 \\
 \hline
 5 = x
 \end{array}$$

$$\text{length} = 2 \times 5 + 6 = 10 + 6 = 16 \text{ cm}$$

$$\text{Area} = L \times W$$

$$\begin{array}{r}
 48 = 16 \times y \\
 \div 16 \quad \div 16 \\
 \hline
 3 = y
 \end{array}$$

$$\therefore y = 3$$

(Total for Question 6 is 4 marks)



7 Brogan needs to draw the graph of $y = x^2 + 1$

Here is her graph.

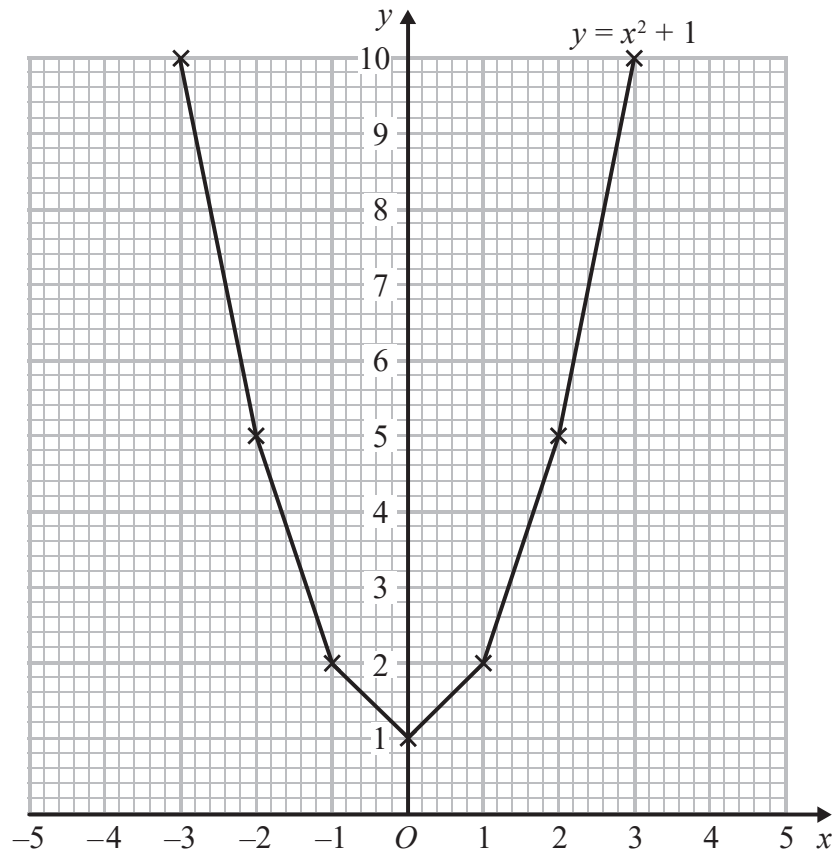

Write down one thing that is wrong with Brogan's graph.

The lines should be drawn free hand
and curved

(Total for Question 7 is 1 mark)



- 8 Write these numbers in order of size.
Start with the smallest number.

| | | | |
|---------------------|---------------|---------------------|---------|
| $0.\dot{2}4\dot{6}$ | $0.24\dot{6}$ | $0.\dot{2}4\dot{6}$ | 0.246 |
| 0.24646 | 0.2466 | 0.246246 | 0.246 |
| 3 | 4 | 2 | 1 |

$$0.246, 0.24\dot{6}, 0.\dot{2}4\dot{6}, 0.246$$

(Total for Question 8 is 2 marks)

- 9 James and Peter cycled along the same 50 km route.

James took $2\frac{1}{2}$ hours to cycle the 50 km.

Peter started to cycle 5 minutes after James started to cycle.
Peter caught up with James when they had both cycled 15 km.

James and Peter both cycled at constant speeds.

Work out Peter's speed.

$$\text{James speed} = \frac{50}{2.5} = 20 \text{ km/h} \quad \text{Speed} = \frac{\text{dis}}{\text{time}}$$

$$\text{Time for James to cycle 15 km} = \frac{15 \text{ km}}{20 \text{ km/h}} = \frac{3}{4} \text{ h} = 45 \text{ min}$$

Peter starts 5 min after

$$45 - 5 \text{ min} = 40 \text{ min} = \frac{2}{3} \text{ hours} \quad \text{Time for Peter to cycle 15 km}$$

$$\text{Peter's speed} = \frac{15}{\frac{2}{3}} = 15 \times \frac{3}{2} = \frac{45}{2} = 22.5 \text{ km/h}$$

22.5 km/h

(Total for Question 9 is 5 marks)



10 (a) Write down the value of $100^{\frac{1}{2}}$

$$100^{\frac{1}{2}} = \sqrt{100} = 10$$

10

(1)

(b) Find the value of $125^{\frac{2}{3}}$

$$\left(\sqrt[3]{125}\right)^2 = 5^2 = 25$$

25

(2)

(Total for Question 10 is 3 marks)

11 3 teas and 2 coffees have a total cost of £7.80
5 teas and 4 coffees have a total cost of £14.20

1
2

Work out the cost of one tea and the cost of one coffee.

$$\textcircled{1} \quad 3t + 2c = 7.80$$

$$\textcircled{2} \quad 5t + 4c = 14.20$$

$$\textcircled{1} \times 2 = 6t + 4c = 15.60$$

$$\textcircled{2} \quad 5t + 4c = 14.20$$

$$t = 1.40$$

$$5 \times 1.4 + 4c = 14.20$$

$$7 + 4c = 14.20$$

$$4c = 7.20$$

$$c = 1.80$$

$$4 \overline{) 7.20} \quad \begin{array}{r} 1.80 \\ \underline{4 } \\ 7.20 \\ \underline{4 } \\ 3.20 \\ \underline{3.20} \\ 0 \end{array}$$

tea £ 1.40

coffee £ 1.80

(Total for Question 11 is 4 marks)

DO NOT WRITE IN THIS AREA

DO NOT WRITE IN THIS AREA

DO NOT WRITE IN THIS AREA



12 The table shows information about the heights, in cm, of a group of Year 11 girls.

| | height (cm) |
|---------------------|-------------|
| least height | 154 |
| median | 165 |
| lower quartile | 161 |
| interquartile range | 7 |
| range | 20 |

greatest height
 $= 154 + 20$
 $= 174$

upper quartile
 $= 161 + 7 = 168$

(a) Draw a box plot for this information.

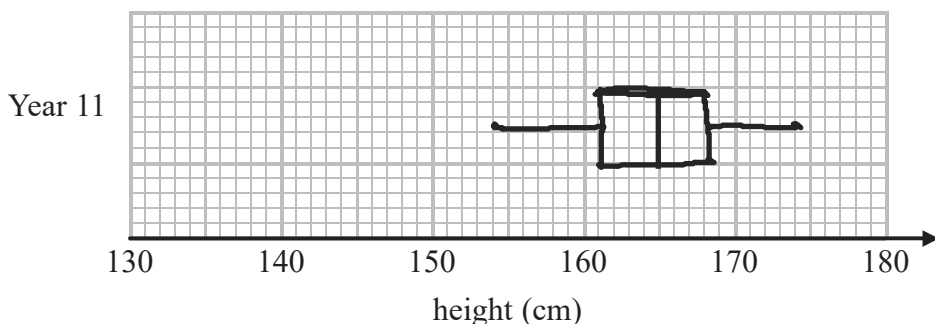

(3)

The box plot below shows information about the heights, in cm, of a group of Year 7 girls.

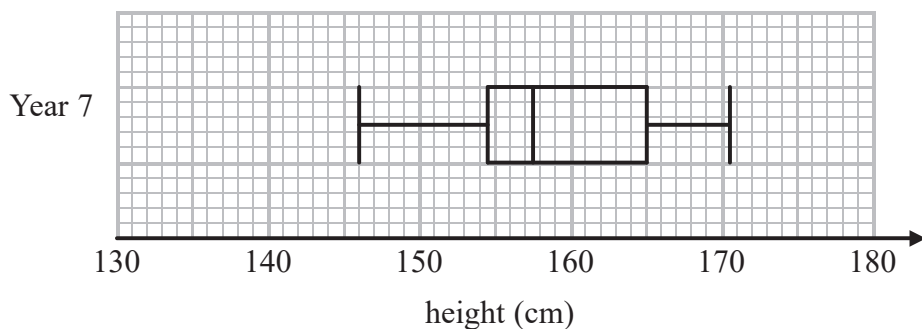

(b) Compare the distribution of heights of the Year 7 girls with the distribution of heights of the Year 11 girls.

Median for Y11 girls (165cm) is greater than Y7 girls (157.5) so Y11 girls are taller on average
 The IQR for Y11 (7) is less than Y7 girls (165 - 154.5 = 10.5) so there is more variation in Y7 girls height

(2)

(Total for Question 12 is 5 marks)

DO NOT WRITE IN THIS AREA

DO NOT WRITE IN THIS AREA

DO NOT WRITE IN THIS AREA



- 13 A factory makes 450 pies every day.
The pies are chicken pies or steak pies.

Each day Milo takes a sample of 15 pies to check.

The proportion of the pies in his sample that are chicken is the same as the proportion of the pies made that day that are chicken.

On Monday Milo calculated that he needed exactly 4 chicken pies in his sample.

- (a) Work out the total number of chicken pies that were made on Monday.

$$\frac{4}{15} = \frac{x}{450}$$

$\xrightarrow{\times 30}$
 $\xrightarrow{\times 30}$

$$4 \times 30 = 120$$

$$\underline{120 \text{ pies}}$$

(2)

On Tuesday, the number of steak pies Milo needs in his sample is 6 correct to the nearest whole number.

Milo takes at random a pie from the 450 pies made on Tuesday.

- (b) Work out the lower bound of the probability that the pie is a steak pie.

$$5.5 \leq \text{steak pie} < 6.5$$

$$\text{prob} = \frac{165}{450}$$

$$\frac{5.5}{15} = \frac{y}{450}$$

$\xrightarrow{\times 30}$

$$5.5 \times 30 = 165$$

$$\underline{165}$$

(2)

(Total for Question 13 is 4 marks)

DO NOT WRITE IN THIS AREA

DO NOT WRITE IN THIS AREA

DO NOT WRITE IN THIS AREA



14 The ratio $(y+x):(y-x)$ is equivalent to $k:1$

Show that $y = \frac{x(k+1)}{k-1}$

$$y+x : y-x = k : 1$$

$$\frac{y+x}{y-x} : 1 = k : 1$$

$$\therefore \frac{y+x}{y-x} = k$$

$$y+x = k(y-x)$$

$$y+x = ky - kx$$

$$kx + x = ky - y$$

$$x(k+1) = y(k-1)$$

$$y = \frac{x(k+1)}{k-1}$$

(Total for Question 14 is 3 marks)

15 $x = 0.4\dot{3}\dot{6}$

Prove algebraically that x can be written as $\frac{24}{55}$

$$x = 0.4363636$$

$$10x = 4.363636$$

$$100x = 43.636363$$

$$1000x = 436.3636$$

$$1000x = 436.3636$$

$$- 10x = 4.3636$$

$$990x = 432$$

$$\therefore x = \frac{432}{990} = \frac{216}{495}$$

$$\frac{216}{495} = \frac{24}{55}$$

(Total for Question 15 is 3 marks)



16 y is directly proportional to $\sqrt[3]{x}$

$$y = 1\frac{1}{6} \text{ when } x = 8$$

Find the value of y when $x = 64$

$$\begin{aligned} y &\propto \sqrt[3]{x} \\ y &= k\sqrt[3]{x} \\ 1\frac{1}{6} &= k\sqrt[3]{8} \\ \frac{7}{6} &= 2k \\ \frac{7}{6} \div 2 & \\ \frac{7}{12} &= k \end{aligned}$$

$$\begin{aligned} x &= 64 \\ y &= \frac{7}{12} \times \sqrt[3]{64} \\ y &= \frac{7}{12} \times 4 = \frac{28}{12} = \frac{7}{3} \\ y &= \frac{7}{3} \end{aligned}$$

(Total for Question 16 is 3 marks)

17 n is an integer.

Prove algebraically that the sum of $\frac{1}{2}n(n+1)$ and $\frac{1}{2}(n+1)(n+2)$ is always a square number.

$$\begin{aligned} &\frac{1}{2}n(n+1) + \frac{1}{2}(n+1)(n+2) \leftarrow n^2 + 2n + n + 2 \\ &= \frac{1}{2}(n^2 + n + n^2 + 3n + 2) \\ &= \frac{1}{2}(2n^2 + 4n + 2) \\ &= n^2 + 2n + 1 \\ &= (n+1)^2 \quad \text{— therefore the answer} \\ &\quad \text{is always a square number} \end{aligned}$$

(Total for Question 17 is 2 marks)

DO NOT WRITE IN THIS AREA

DO NOT WRITE IN THIS AREA

DO NOT WRITE IN THIS AREA



18

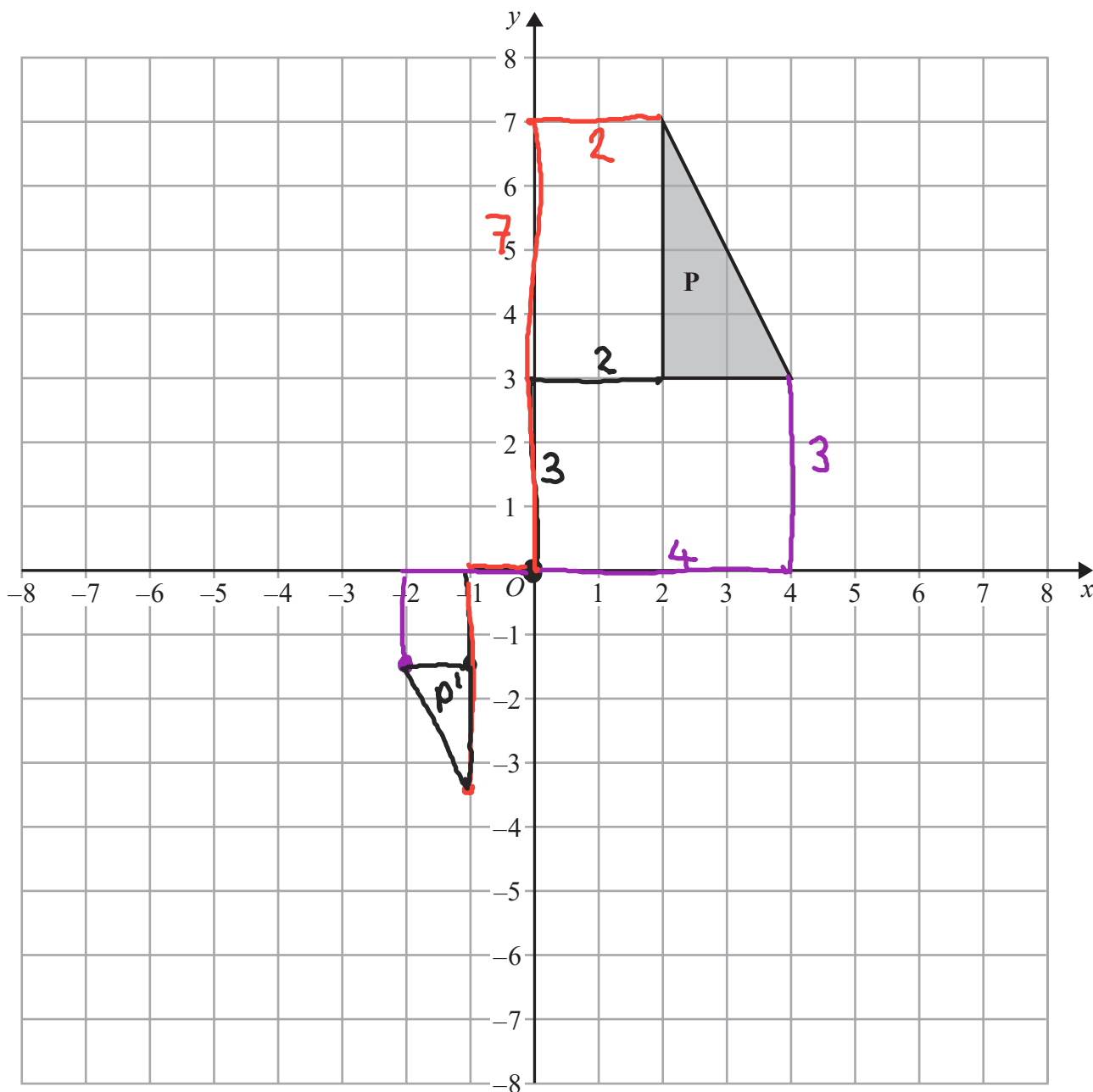

Enlarge shape **P** by scale factor $-\frac{1}{2}$ with centre of enlargement $(0, 0)$.

Label your image **Q**.

$\frac{1}{2}$ = shrink by 2 - = shape is enlarged in opp direction
 (Total for Question 18 is 2 marks)

DO NOT WRITE IN THIS AREA

DO NOT WRITE IN THIS AREA

DO NOT WRITE IN THIS AREA



19

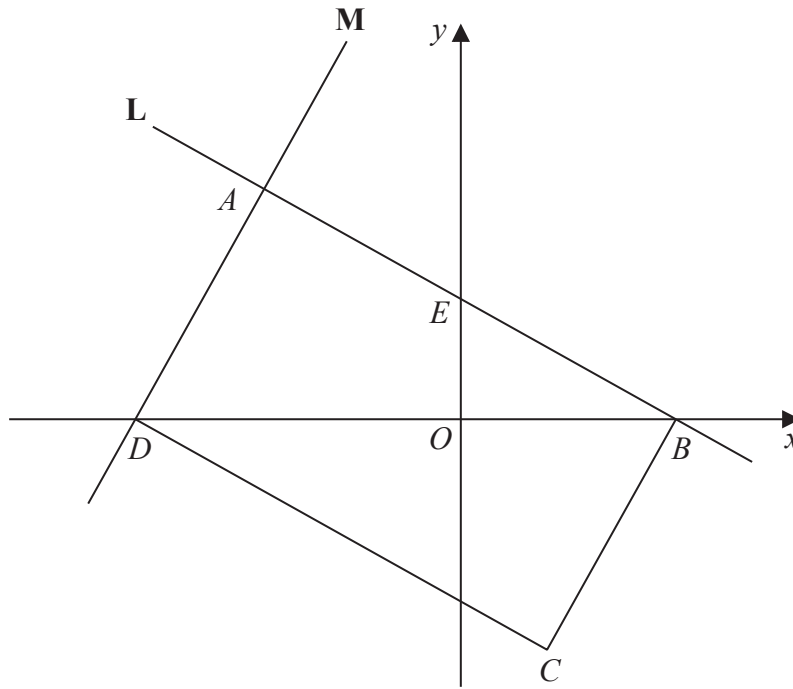

$ABCD$ is a rectangle.

A , E and B are points on the straight line L with equation $x + 2y = 12$
 A and D are points on the straight line M .

$AE = EB$

Find an equation for M .

$$2y = 12 - x$$

$$y = 6 - \frac{1}{2}x$$

$$E = x=0 = (0, 6)$$

$$B = y=0 = (12, 0)$$

$$A = (0 - 12, 6 + 6) = (-12, 12)$$

AD is perpendicular to AB

therefore gradient is neg reciprocal of $-\frac{1}{2} = 2$

$$m = 2 \quad x = -12 \quad y = 12$$

$$y = mx + c \quad 12 = -24 + c$$

$$12 = -12 \times 2 + c$$

$$c = 36$$

$$y = 2x + 36$$

(Total for Question 19 is 4 marks)

DO NOT WRITE IN THIS AREA

DO NOT WRITE IN THIS AREA

DO NOT WRITE IN THIS AREA



20 The table shows some values of x and y that satisfy the equation $y = a \cos x^\circ + b$

| | | | | | | | | |
|-----|---|----------------|----|----|-----|----------------|-----|--|
| | 1 | | | 2 | | | | |
| x | 0 | 30 | 60 | 90 | 120 | 150 | 180 | |
| y | 3 | $1 + \sqrt{3}$ | 2 | 1 | 0 | $1 - \sqrt{3}$ | -1 | |

Find the value of y when $x = 45$

$$3 = a \cos 0 + b$$

$$3 = a + b$$

$$1 = a \cos 90 + b$$

$$b = 1$$

$$a = 2$$

$$\cos 0 = 1$$

$$\cos 90 = 0$$

$$y = 2 \cos 45 + 1$$

$$y = 2 \times \frac{\sqrt{2}}{2} + 1 = \sqrt{2} + 1$$

(Total for Question 20 is 4 marks)

21 Show that $\frac{6 - \sqrt{8}}{\sqrt{2} - 1}$ can be written in the form $a + b\sqrt{2}$ where a and b are integers.

$$\frac{6 - \sqrt{8}}{\sqrt{2} - 1} \times (\sqrt{2} + 1)$$

$$\frac{6\sqrt{2} + 6 - \sqrt{16} - \sqrt{8}}{2 + \sqrt{2} - \sqrt{2} - 1} = \frac{6\sqrt{2} + 6 - 4 - 2\sqrt{2}}{1} = 2 + 4\sqrt{2}$$

$$\frac{6\sqrt{2} + 6 - \sqrt{16} - \sqrt{8}}{2 + \sqrt{2} - \sqrt{2} - 1} = \frac{6\sqrt{2} + 6 - 4 - 2\sqrt{2}}{1} = 2 + 4\sqrt{2}$$

$$= 2 + 4\sqrt{2}$$

(Total for Question 21 is 3 marks)

DO NOT WRITE IN THIS AREA

DO NOT WRITE IN THIS AREA

DO NOT WRITE IN THIS AREA



22 The two triangles in the diagram are similar.

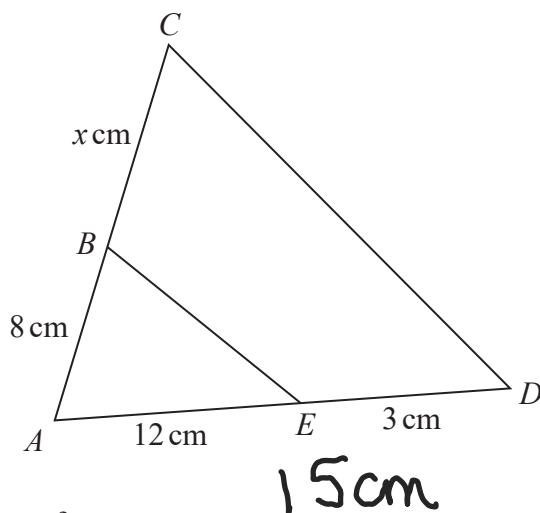

There are two possible values of x .

Work out each of these values.

State any assumptions you make in your working.

$$\frac{12}{3} = \frac{8}{x} \qquad \frac{8}{x} = 4 \qquad x = 2$$

$$8 = 4x$$

The triangles are similar so the lengths are in the same ratio

OR

$$\frac{x+8}{12} = \frac{12+3}{8}$$

$$\frac{x+8}{12} = \frac{15}{8}$$

$$8x + 64 = 180$$

$$8x = 116$$

$$\begin{array}{r} 15x \\ 12 \\ \hline 150 \\ 30 \\ \hline 180 \end{array}$$

$$8 \overline{) 116.0} \begin{array}{l} 14.5 \\ \underline{8} \\ 36 \\ \underline{32} \\ 40 \\ \underline{40} \\ 0 \end{array}$$

$$x = 14.5 \text{ cm}$$

$$x = 2 \text{ cm}$$

$$\text{or } 14.5 \text{ cm}$$

(Total for Question 22 is 5 marks)



23 Here is a rectangle and a right-angled triangle.

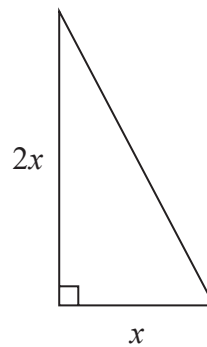
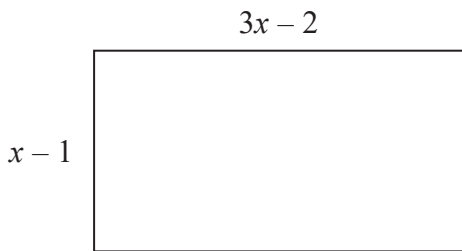

All measurements are in centimetres.

The area of the rectangle is greater than the area of the triangle.

Find the set of possible values of x .

Area of rectangle
 $= (3x - 2)(x - 1)$
 $= 3x^2 - 3x - 2x + 2$
 $= 3x^2 - 5x + 2$

Area of tri
 $= \frac{1}{2} \times 2x \times x$
 $= x^2$

$$3x^2 - 5x + 2 > x^2$$

$$2x^2 - 5x + 2 > 0$$

$2 \times 2 = 4$

$$2x^2 - 4x - x + 2 > 0$$

$$2x(x - 2) - (x - 2)$$

∴

$$(2x - 1)(x - 2) > 0$$

$x < \frac{1}{2} \qquad x > 2$

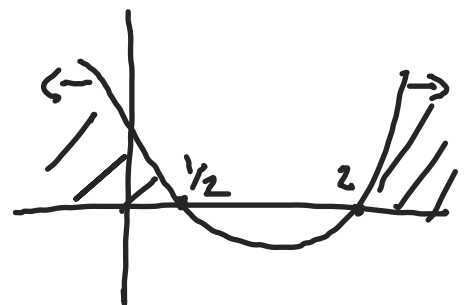

$x > 2$

x can't be $< \frac{1}{2}$ as the width of the rectangle would be negative

(Total for Question 23 is 5 marks)

TOTAL FOR PAPER IS 80 MARKS

DO NOT WRITE IN THIS AREA

DO NOT WRITE IN THIS AREA

DO NOT WRITE IN THIS AREA



DO NOT WRITE IN THIS AREA

DO NOT WRITE IN THIS AREA

DO NOT WRITE IN THIS AREA

BLANK PAGE

