

Please check the examination details below before entering your candidate information

Candidate surname					Other names				
Centre Number					Candidate Number				
<b>Pearson Edexcel</b> <b>Level 1/Level 2 GCSE (9–1)</b>					<input type="text"/> <input type="text"/> <input type="text"/> <input type="text"/> <input type="text"/>				
<h1>Tuesday 5 November 2019</h1>									
Morning (Time: 1 hour 30 minutes)					Paper Reference <b>1MA1/1F</b>				
<h2>Mathematics</h2> <h3>Paper 1 (Non-Calculator)</h3> <h3>Foundation Tier</h3>									
<b>You must have:</b> Ruler graduated in centimetres and millimetres, protractor, pair of compasses, pen, HB pencil, eraser. Tracing paper may be used.								Total Marks	

### Instructions

- Use **black** ink or ball-point pen.
- **Fill in the boxes** at the top of this page with your name, centre number and candidate number.
- Answer **all** questions.
- Answer the questions in the spaces provided  
– *there may be more space than you need.*
- You must **show all your working**.
- Diagrams are **NOT** accurately drawn, unless otherwise indicated.
- **Calculators may not be used.**



### Information

- The total mark for this paper is 80
- The marks for **each** question are shown in brackets  
– *use this as a guide as to how much time to spend on each question.*

### Advice

- Read each question carefully before you start to answer it.
- Keep an eye on the time.
- Try to answer every question.
- Check your answers if you have time at the end.

Turn over ►

P58865A

©2019 Pearson Education Ltd.

6/1/1



Pearson

Answer ALL questions.

Write your answers in the spaces provided.

You must write down all the stages in your working.

- 1 Write down the value of the 7 in the number 1074

thousands hundreds tens units

70

(Total for Question 1 is 1 mark)

- 2 Write 4.58 correct to 1 decimal place.

8 is more than 5 so round up  
.5 → .6

4.6

(Total for Question 2 is 1 mark)

- 3 Work out  $31.7 \times 100$

$\times 100 =$  shift decimal point two digits right  
31.700 → 3170

3170

(Total for Question 3 is 1 mark)

- 4 Write the fraction  $\frac{28}{70}$  in its simplest form.

$$\frac{28}{70} = \frac{2}{5}$$

$\div 14$

$\frac{2}{5}$

(Total for Question 4 is 1 mark)

- 5 Write 15% as a decimal.

$$15\% = 15 \text{ out of } 100$$

$$15 \div 100 = 0.15$$

0.15

(Total for Question 5 is 1 mark)

DO NOT WRITE IN THIS AREA

DO NOT WRITE IN THIS AREA

DO NOT WRITE IN THIS AREA



DO NOT WRITE IN THIS AREA

6 The pictogram shows information about the number of pictures sold in an art shop in each of January, February and March.

January	<input type="checkbox"/>	<input type="checkbox"/>	<input type="checkbox"/>	
February	<input type="checkbox"/>	<input type="checkbox"/>	<input type="checkbox"/>	<input type="checkbox"/>
March	<input type="checkbox"/>	<input type="checkbox"/>	<input type="checkbox"/>	
April	<input type="checkbox"/>	<input type="checkbox"/>		

**Key:**

represents 8 pictures

(a) Write down the number of pictures sold in January.

$3 \square = 3 \times 8 = 24$

$\square = 8$

24

(1)

12 pictures were sold in April.

(b) Show this information on the pictogram.

$12 \div 8 = 1.5 = \square \sqsupset$

(1)

(c) What was the total number of pictures sold in these four months?

$9 \square = 9 \times 8 = 72$

$3 \sqsupset = 3 \times 4 = 12 \leftarrow \sqsupset = \frac{1}{2} \text{ of } 8 = 4$

$72 + 12 = 84$

84

(2)

(Total for Question 6 is 4 marks)

DO NOT WRITE IN THIS AREA

7 Work out the difference, in minutes, between 1 hour 25 minutes and  $1\frac{1}{4}$  hours.

1 hour 25 minutes = 60 minutes + 25 minutes = 85 minutes

$\uparrow$  1 hour = 60 minutes

$1\frac{1}{4}$  hours = 60 minutes + ( $\frac{1}{4} \times 60$  minutes) = 60 + 15 = 75 minutes

$\hookrightarrow \frac{1}{4} \times 60 = \frac{60}{4} = 15$

$85 - 75 = 10$  minutes

10

minutes

(Total for Question 7 is 2 marks)

DO NOT WRITE IN THIS AREA



- 8 Prasha has five blocks of wood.

The total weight of all five blocks of wood is 3 kilograms.  
4 of the blocks of wood each have a weight of 650 grams.

Work out the weight, in grams, of the other block of wood.

$$3 \text{ kilograms} = 3000 \text{ grams}$$

$$4 \times 650 = 2600 \text{ grams}$$

$$3000 - 2600 = 400 \text{ grams}$$

$1 \text{ kg} = 1000 \text{g}$

total weight of the 4 blocks

..... 400 ..... grams

(Total for Question 8 is 3 marks)

- 9  $PQR$  is a straight line.

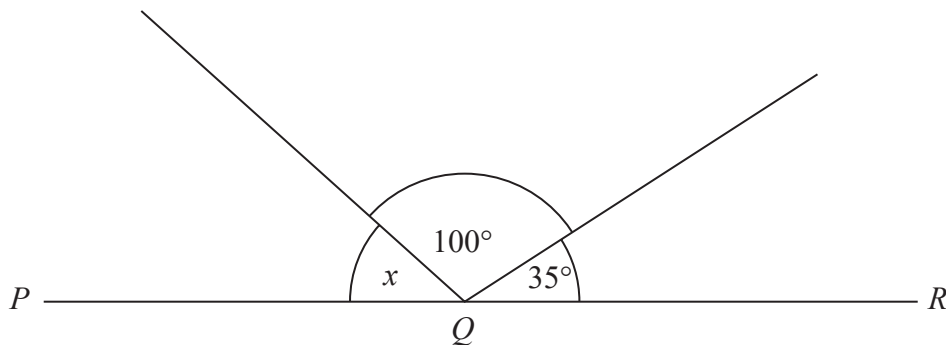

Work out the size of angle  $x$ .

$$\text{sum of angles on a straight line} = 180^\circ$$

$$180^\circ - 100^\circ - 35^\circ = 45^\circ$$

..... 45 ..... °

(Total for Question 9 is 2 marks)



10

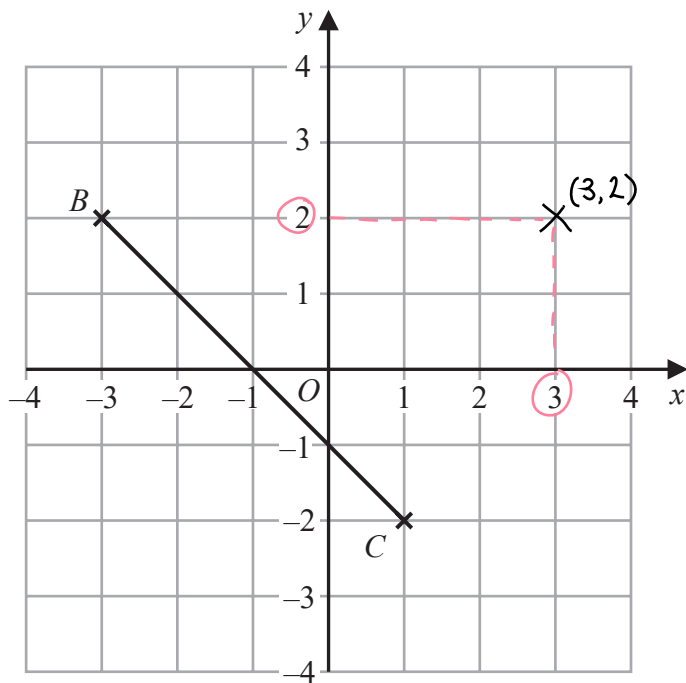

- (a) Plot the point with coordinates (3, 2)  
Label this point A.

*x-axis* *y-axis*

(1)

- (b) Write down the coordinates of the midpoint of BC.

*Use a ruler to measure the length of BC.  
Divide the length by 2 and write the point.*

( *-1* , *0* )  
(1)

(Total for Question 10 is 2 marks)

- 11 Mason throws a coin 3 times.  
The outcome of each throw is either Heads or Tails.

List all the possible outcomes of the 3 throws.

Heads = H

Tails = T

HHT HHH HTT HTH

TTT TTH THH THT

(Total for Question 11 is 2 marks)



DO NOT WRITE IN THIS AREA

DO NOT WRITE IN THIS AREA

DO NOT WRITE IN THIS AREA

12 Rehan is on holiday in the USA.

He has \$200 to spend on clothes.

Rehan buys

- 1 pair of trainers costing \$60
- 3 T-shirts costing \$25 each.

He also wants to buy a jacket costing \$80

- (a) Has Rehan got enough money to buy the jacket?  
You must show how you get your answer.

$$1 \times \$60 = \$60$$

$$3 \times \$25 = \$75$$

$$\text{Total spent: } \$60 + \$75 = \$135$$

$$\text{Total left: } \$200 - \$135 = \$65$$

$$\begin{array}{r} 3 \times 25: \quad 3 \times 20 = 60 \\ \quad \quad \quad + 3 \times 5 = 15 \\ \hline \quad \quad \quad 75 \end{array}$$

$$\begin{array}{r} \overset{60}{\cancel{2}} \overset{0}{\cancel{0}} \\ - 135 \\ \hline 065 \end{array}$$

\$65 is less than \$80, so he does not have enough money to buy the jacket.

(3)

The trainers cost \$60

The exchange rate is \$1 = £0.749

Rehan says,

“The trainers cost less than £40”

Rehan is wrong.

- (b) Using a suitable approximation, show working to explain why.

$$£0.749 \approx £0.7$$

round down to 1dp

$$60 \times £0.7 = £42$$

$$\begin{aligned} 60 \times 0.7 &= \frac{60 \times 7}{10} \\ &= \frac{420}{10} \\ &= 42 \end{aligned}$$

£42 is more than £40 so Rehan is wrong.

(2)

(Total for Question 12 is 5 marks)

DO NOT WRITE IN THIS AREA

DO NOT WRITE IN THIS AREA

DO NOT WRITE IN THIS AREA



13 (a) Simplify  $2a \times 5b$ 

$$2a \times 5b = 2 \times a \times 5 \times b = (2 \times 5) \times (a \times b) \\ = 10ab$$

$$\underline{\hspace{1cm} 10ab \hspace{1cm}} \\ (1)$$

(b) Simplify  $3x + 2y + 5x - y$ 

$$3x + 2y + 5x - y = (3x + 5x) + (2y - y) \\ = 8x + y \quad \text{collect like terms}$$

$$\underline{\hspace{1cm} 8x + y \hspace{1cm}} \\ (2)$$

(Total for Question 13 is 3 marks)

14 Work out  $23 \times 15$ 

x	10	5
20	200	100
3	30	15

OR

	2	3
x	1	5
$20 \times 10$	2	0
$3 \times 5$	1	5
$20 \times 5$	1	0
$3 \times 10$	3	0
	3	45

$$200 + 100 + 30 + 15 = 345$$

$$\underline{\hspace{1cm} 345 \hspace{1cm}}$$

(Total for Question 14 is 2 marks)



15 120 people were at a hockey match.

Each person was asked if they wanted to stand or to sit to watch the match.

- 75 of the people were female
- 29 of the males wanted to stand
- 30 of the people wanted to sit

(a) Use this information to complete the frequency tree.

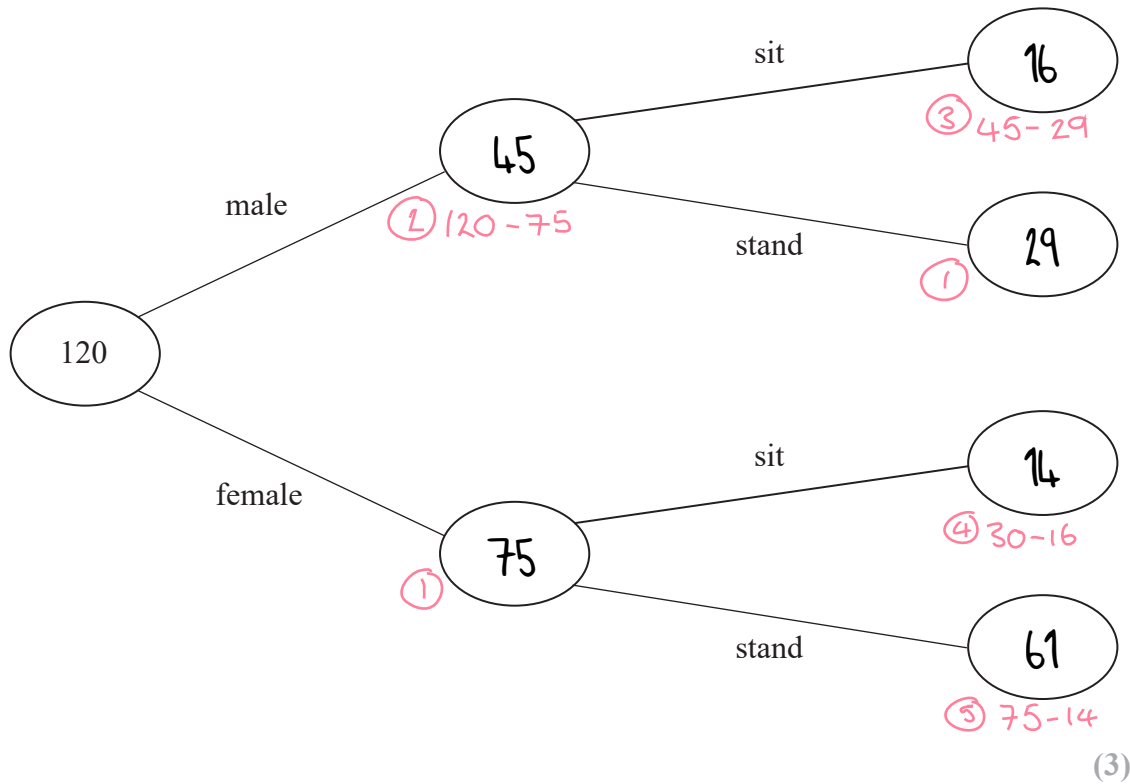

One of the 120 people is chosen at random.

(b) Write down the probability that this person is a male who wanted to stand.

29 males who want to stand out of 120 people =  $\frac{29}{120}$

$$\frac{29}{120}$$

(1)

(Total for Question 15 is 4 marks)

DO NOT WRITE IN THIS AREA

DO NOT WRITE IN THIS AREA

DO NOT WRITE IN THIS AREA





- 16 Steve drove from his home to his friend's house.  
He stayed at his friend's house and then drove home.

Here is Steve's travel graph.

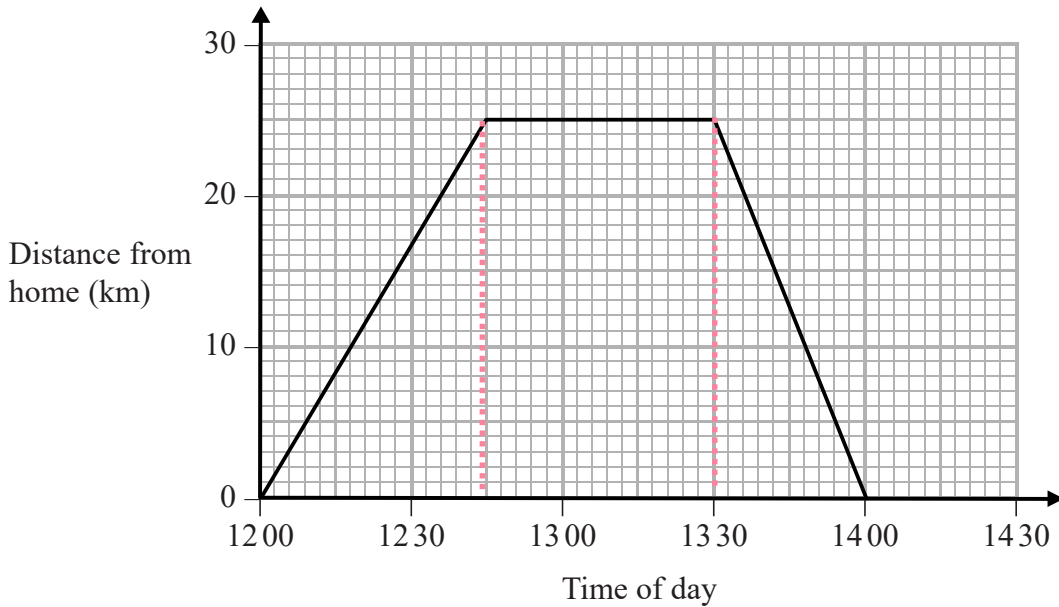

- (a) For how many minutes did Steve stay at his friend's house?

*stationary time: where the line is horizontal*

12:45 to 13:30 = 45 minutes

..... 45 ..... minutes  
(1)

- (b) What was Steve's average speed on his journey home?

speed =  $\frac{\text{distance}}{\text{time}} = \frac{25}{0.5} = 50 \text{ km/h}$   
*vertical (y) value on graph*  
*30 mins = 1/2 hour*

..... 50 ..... km/h  
(2)

(Total for Question 16 is 3 marks)



DO NOT WRITE IN THIS AREA

DO NOT WRITE IN THIS AREA

DO NOT WRITE IN THIS AREA

$$17 \quad x - 1 = 2$$

Work out the value of  $2x^2$

$$\begin{array}{l} x - 1 = 2 \\ +1 \quad \left( \quad \right) +1 \\ \hline x = 3 \end{array}$$

Apply BIDMAS - indices first, then  $\times 2$ .

$$2(x^2) = 2(3^2) = 2(9) = 18$$

$x=3$       $3^2=9$       $9 \times 2=18$

18

(Total for Question 17 is 3 marks)

DO NOT WRITE IN THIS AREA

DO NOT WRITE IN THIS AREA

DO NOT WRITE IN THIS AREA



18 The pie charts show information about the favourite animal of each student at school A and of each student at school B.

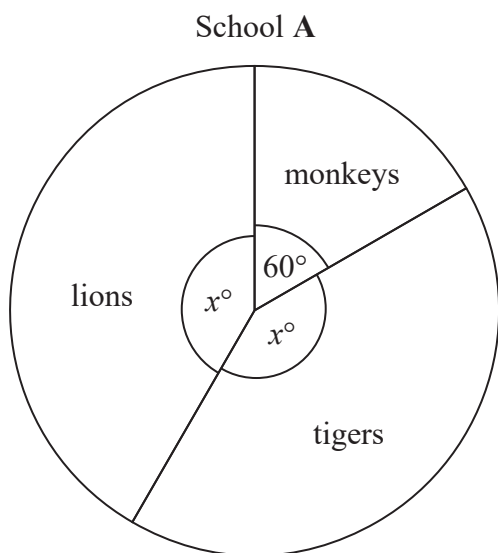

There are 480 students at school A.

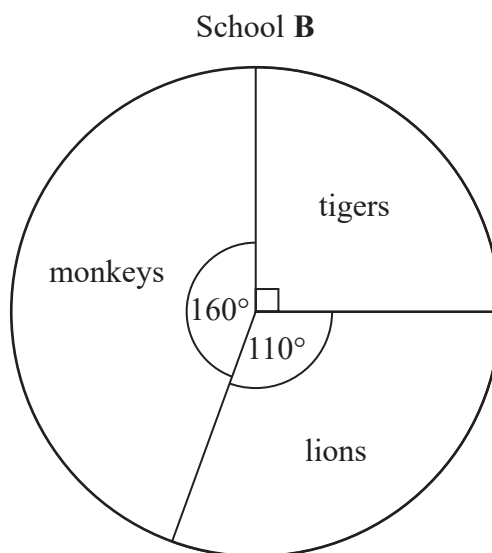

There are 760 students at school B.

Henry says,

“The same number of students at each school have tigers as their favourite animal.”

Is Henry correct?

You must show how you get your answer.

School A:

*360° in a circle*

$$\begin{aligned}
 x + x + 60^\circ &= 360^\circ \\
 2x &= 300^\circ \\
 x &= 150^\circ \\
 \frac{150}{360} \times 480 &= 200
 \end{aligned}$$

There are 200 students who have tigers as their favourite animal in School A.

School B:

*360° in a circle*

$$\begin{aligned}
 160^\circ + 110^\circ + 90^\circ &= 360^\circ \\
 \frac{90}{360} \times 760 &= 190
 \end{aligned}$$

There are 190 students who have tigers as their favourite animal in School B.

Henry is not correct because  $200 \neq 190$

(Total for Question 18 is 4 marks)



DO NOT WRITE IN THIS AREA

DO NOT WRITE IN THIS AREA

DO NOT WRITE IN THIS AREA

19 Here is a number line:

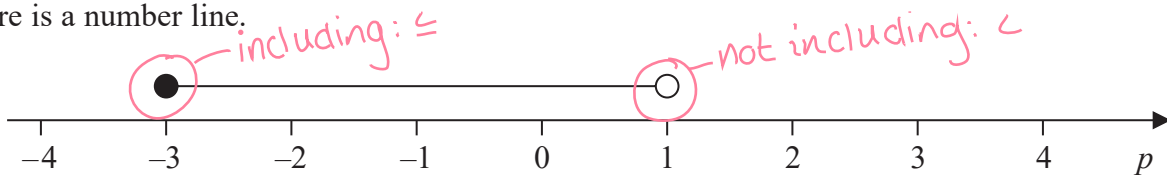

Write down the inequality shown on the number line.

$$-3 \leq p < 1$$

$$-3 \leq p < 1$$

(Total for Question 19 is 2 marks)

20 Find the Lowest Common Multiple (LCM) of 108 and 120

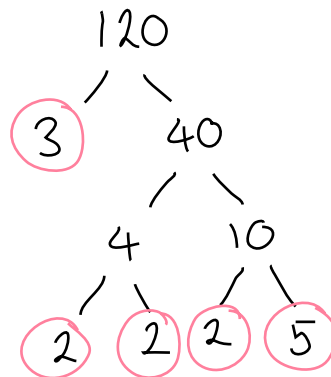
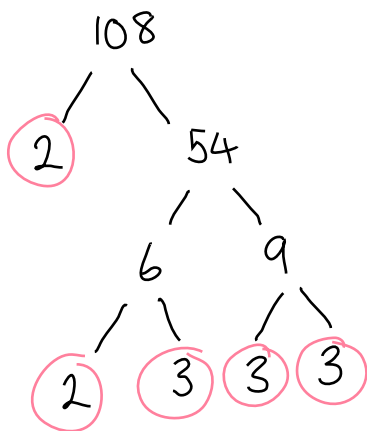

$$108 = 2 \times 2 \times 3 \times 3 \times 3$$

$$120 = 3 \times 2 \times 2 \times 2 \times 5$$

common factors:  $2 \times 2 \times 3 = 12$

$$\text{LCM: } 12 \times 3 \times 3 \times 2 \times 5 = 1080$$

1080

(Total for Question 20 is 3 marks)

DO NOT WRITE IN THIS AREA

DO NOT WRITE IN THIS AREA

DO NOT WRITE IN THIS AREA



- 21 There are 60 people in a choir.  
Half of the people in the choir are women.

The number of women in the choir is 3 times the number of men in the choir.  
The rest of the people in the choir are children.

the number of children in the choir : the number of men in the choir =  $n : 1$

Work out the value of  $n$ .

You must show how you get your answer.

$$60 \div 2 = 30 \text{ women in the choir}$$

↖ half ( $\frac{1}{2}$ ) are women.

$$30 \div 3 = 10 \text{ men in the choir}$$

↖ third ( $\frac{1}{3}$ ) of women = men

$$60 - 10 - 30 = 20 \text{ children in the choir}$$

↖ rest are children

children : men  $\div 10$

$$20 : 10 = 2 : 1 \quad \text{so } n = 2$$

$(n : 1)$

$$n = \dots\dots\dots 2 \dots\dots\dots$$

(Total for Question 21 is 4 marks)

- 22 Work out  $1\frac{3}{4} \times 1\frac{1}{3}$

Give your answer as a mixed number.

$$1 = \frac{4}{4} \text{ so } 1\frac{3}{4} = \frac{4}{4} + \frac{3}{4} = \frac{4+3}{4} = \frac{7}{4}$$

$$1 = \frac{3}{3} \text{ so } 1\frac{1}{3} = \frac{3}{3} + \frac{1}{3} = \frac{3+1}{3} = \frac{4}{3}$$

↖ make top-heavy fractions.

$$1\frac{3}{4} \times 1\frac{1}{3} = \frac{7}{4} \times \frac{4}{3}$$

$$= \frac{7 \times 4}{4 \times 3}$$

$$= \frac{28}{12}$$

$$2 \times 12 = 24$$

$$\text{so } \frac{28}{12} = 2\frac{4}{12} \text{ or}$$

$$\dots\dots\dots 2\frac{1}{3} \dots\dots\dots$$

(Total for Question 22 is 3 marks)



- 23 Use a ruler and compasses to construct the line from the point  $P$  perpendicular to the line  $CD$ . You must show **all** construction lines.

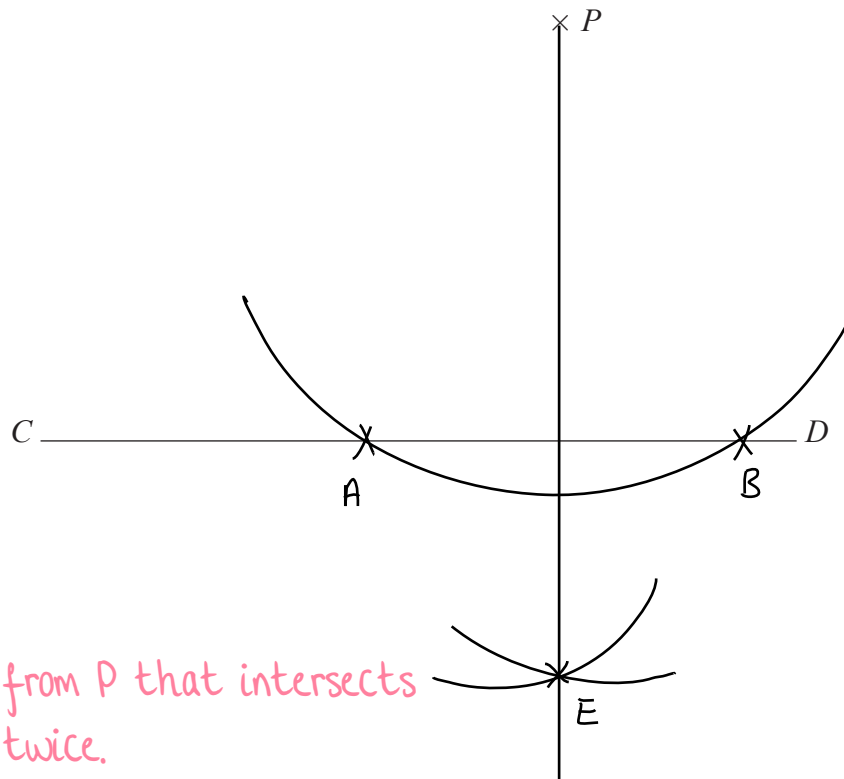

1. Draw an arc from  $P$  that intersects the line  $CD$  twice.
2. Set the compass to a shorter width and draw an arc from  $A$ .
3. Draw an arc of the same width from  $B$ . Label the intersection  $E$ .
4. Connect points  $P$  and  $E$  with a straight line (use a ruler).

(Total for Question 23 is 2 marks)

DO NOT WRITE IN THIS AREA

DO NOT WRITE IN THIS AREA

DO NOT WRITE IN THIS AREA



24 The diagram shows triangle  $ABC$ .

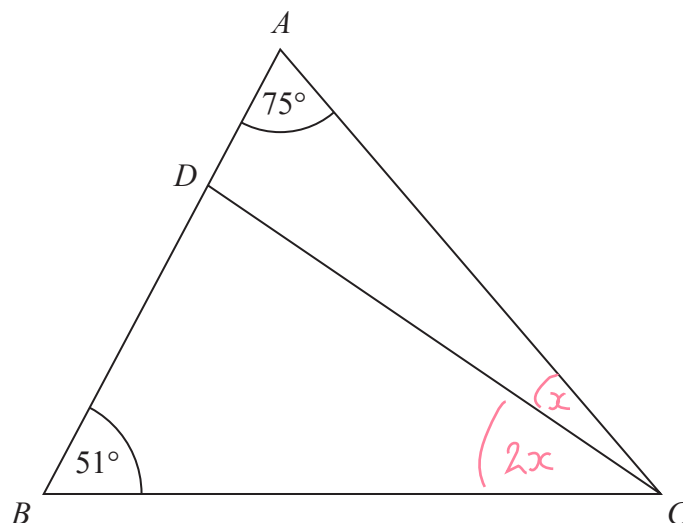

$ADB$  is a straight line.

the size of angle  $DCB$  : the size of angle  $ACD = 2 : 1$

Work out the size of angle  $BDC$ .

$$\begin{aligned}
 & \text{from ratio} && 180^\circ \text{ in a triangle} \\
 75^\circ + 51^\circ + 2x + x &= 180^\circ && \text{collect terms} \\
 126^\circ + 3x &= 180^\circ && \\
 3x &= 54^\circ && -126 \\
 18^\circ &= x && \div 3
 \end{aligned}$$

$$\hat{DCB} = 2x = 2(18) = 36^\circ$$

$$\hat{BDC} = 180^\circ - 36^\circ - 51^\circ = 93^\circ$$

$180^\circ$  in a triangle

..... 93 .....

(Total for Question 24 is 4 marks)



- 25 4 red bricks have a mean weight of 5 kg.  
5 blue bricks have a mean weight of 9 kg.  
1 green brick has a weight of 6 kg.

Donna says,

“The mean weight of the 10 bricks is less than 7 kg.”

Is Donna correct?

You must show how you get your answer.

$$4 \times 5\text{Kg} = 20\text{Kg}$$

$$5 \times 9\text{Kg} = 45\text{Kg}$$

$$1 \times 6\text{Kg} = 6\text{Kg}$$

$$\frac{20 + 45 + 6}{4 + 5 + 1} = \frac{71}{10} = 7.1\text{Kg}$$

$$\text{mean} = \frac{\text{total of weights}}{\text{number of bricks}}$$

$$\text{mean} \times \text{number of bricks} = \text{total of weights}$$

$7.1\text{Kg} > 7\text{Kg}$  so Donna is not correct.

(Total for Question 25 is 3 marks)

DO NOT WRITE IN THIS AREA

DO NOT WRITE IN THIS AREA

DO NOT WRITE IN THIS AREA





26 (a) Simplify  $(p^2)^5$ 

$$(p^2)^5 = p^{2 \times 5} = p^{10}$$

$$(m^a)^b = m^{a \times b}$$

$$p^{10}$$

(1)

(b) Simplify  $12x^7y^3 \div 6x^3y$ 

$$12x^7y^3 \div 6x^3y = \frac{12}{6} x^{7-3} y^{3-1} = 2x^4y^2$$

$$m^a \div m^b = m^{a-b}$$

$$2x^4y^2$$

(2)

(Total for Question 26 is 3 marks)

DO NOT WRITE IN THIS AREA

DO NOT WRITE IN THIS AREA

DO NOT WRITE IN THIS AREA



27 The accurate scale drawing shows the positions of port  $P$  and a lighthouse  $L$ .

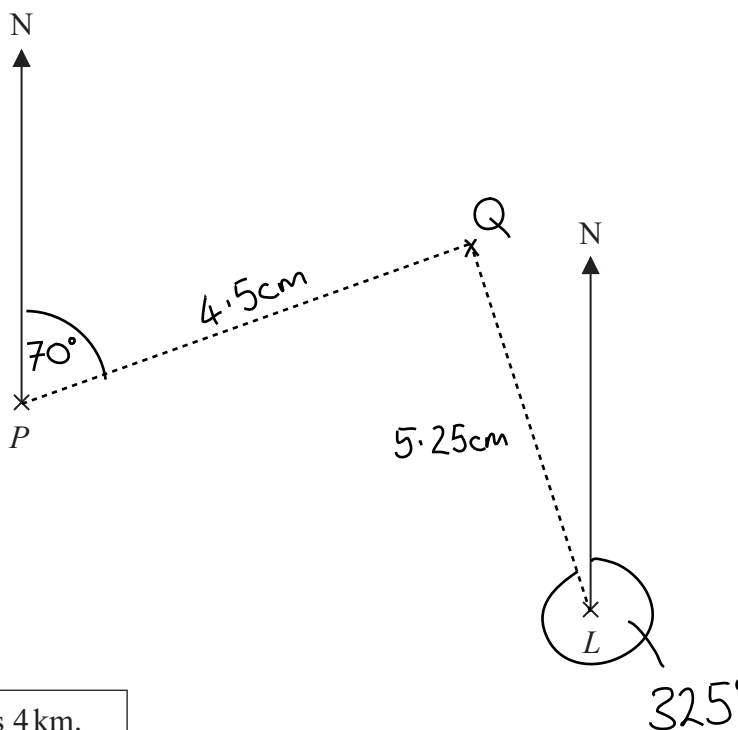

Scale: 1 cm represents 4 km.

Aleena sails her boat from port  $P$  on a bearing of  $070^\circ$

She sails for  $1\frac{1}{2}$  hours at an average speed of 12 km/h to a port  $Q$ .

Find

- (i) the distance, in km, of port  $Q$  from lighthouse  $L$ ,
- (ii) the bearing of port  $Q$  from lighthouse  $L$ .

i) speed = distance  $\div$  time      so      distance = speed  $\times$  time  
 $\phantom{i)} = 12 \times 1.5$   
 $\phantom{i)} = 18\text{Km}$

$18\text{Km} \div 4\text{Km} = 4.5\text{cm}$  so  $Q$  is 4.5cm from  $P$   
 Measure  $070^\circ$  from North with a protractor and mark  $Q$  4.5cm from  $P$ .  
 Measure distance  $QL$  (about 5.25cm).  
 $5.25 \times 4 = 21\text{Km}$

ii) Using a protractor, measure angle clockwise from  $L$  to  $Q$ . (about  $325^\circ$ )

distance  $QL = \dots\dots\dots 21 \dots\dots\dots$  km  
 bearing of  $Q$  from  $L = \dots\dots\dots 325 \dots\dots\dots$   $^\circ$

(Total for Question 27 is 5 marks)



28 The diagram shows triangle  $AOB$ .

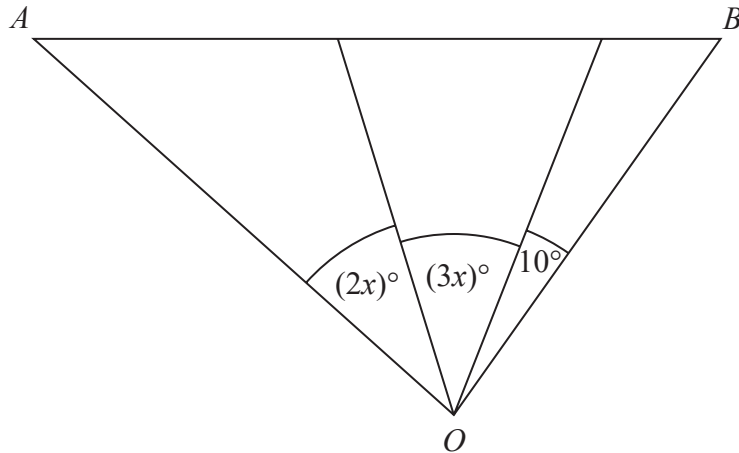

Angle  $AOB$  is **not** an obtuse angle.

Find the greatest value of  $x$ .

You must show all your working.

Obtuse angle: more than  $90^\circ$ . So  $AOB$  must be  $90^\circ$  or less.

$$2x + 3x + 10^\circ \leq 90^\circ$$

$$5x + 10^\circ \leq 90^\circ$$

$$-10^\circ \left( \begin{array}{l} \rightarrow \\ \div 5 \end{array} \right. \left. \begin{array}{l} \rightarrow \\ \div 5 \end{array} \right) 5x \leq 80^\circ$$

$$\div 5 \left( \begin{array}{l} \rightarrow \\ \div 5 \end{array} \right) x \leq 16$$

So the greatest value of  $x$  is 16.

16

(Total for Question 28 is 3 marks)



29  $ABC$  and  $PQR$  are similar right-angled triangles.

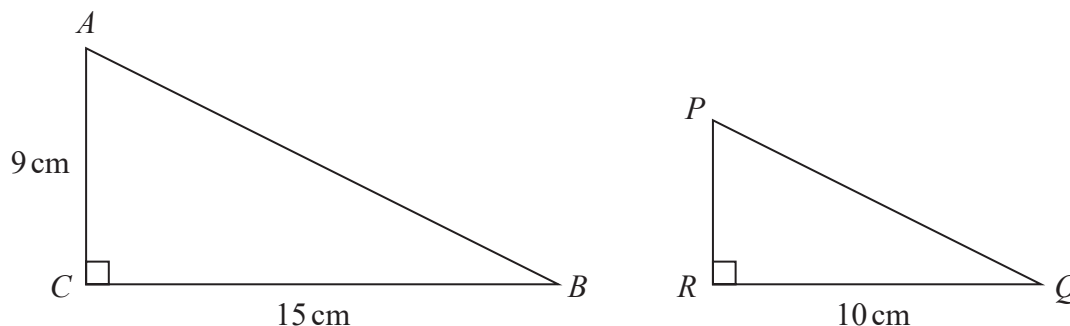

angle  $ABC =$  angle  $PQR$

(a) Work out the length of  $PR$ .

$RQ$  is  $\frac{10}{15} = \frac{2}{3}$  of  $CB$  so scale factor is  $\frac{2}{3}$   
 $9 \times \frac{2}{3} = 6$  so  $PR$  is 6cm

..... 6 ..... cm  
 (2)

Triangle  $EGH$  is congruent to triangle  $KGF$ .

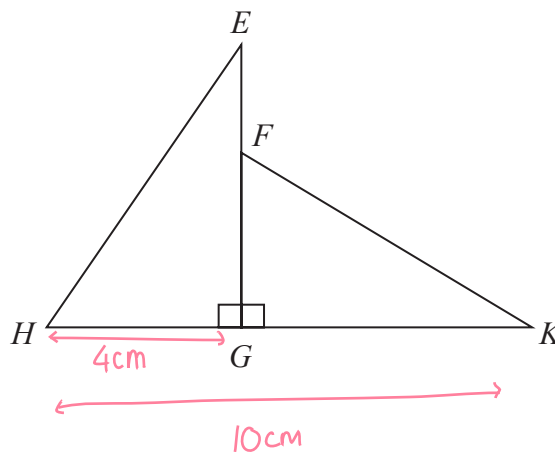

$HK = 10$  cm.  
 $HG = 4$  cm.

(b) Work out the length of  $EF$ .

Triangles are congruent so all corresponding side lengths are equal.  
 $GK = HK - HG = 10 - 4 = 6$ cm  
 $HG = FG = 4$ cm and  $GK = EG = 6$ cm  
 $EF = EG - FG = 6 - 4 = 2$ cm

..... 2 ..... cm  
 (2)

(Total for Question 29 is 4 marks)

TOTAL FOR PAPER IS 80 MARKS

DO NOT WRITE IN THIS AREA

DO NOT WRITE IN THIS AREA

DO NOT WRITE IN THIS AREA

