

# OCR

Oxford Cambridge and RSA

## Monday 22 May 2023 – Morning

### GCSE (9–1) Chemistry A (Gateway Science)

**J248/03** Paper 3 (Higher Tier)

**Time allowed: 1 hour 45 minutes**

**You must have:**

- a ruler (cm/mm)
- the Data Sheet for GCSE (9–1) Chemistry A (inside this document)

**You can use:**

- a scientific or graphical calculator
- an HB pencil



Please write clearly in black ink. **Do not write in the barcodes.**

Centre number

--	--	--	--	--

Candidate number

--	--	--	--

First name(s)

---

Last name

---

#### INSTRUCTIONS

- Use black ink. You can use an HB pencil, but only for graphs and diagrams.
- Write your answer to each question in the space provided. If you need extra space use the lined pages at the end of this booklet. The question numbers must be clearly shown.
- Answer **all** the questions.
- Where appropriate, your answer should be supported with working. Marks might be given for using a correct method, even if the answer is wrong.

#### INFORMATION

- The total mark for this paper is **90**.
- The marks for each question are shown in brackets [ ].
- Quality of extended response will be assessed in questions marked with an asterisk (\*).
- This document has **28** pages.

#### ADVICE

- Read each question carefully before you start your answer.

## 2

## Section A

You should spend a **maximum of 30 minutes** on this section.

Write your answer to each question in the box provided.

1 Which term is a correct description of ice turning from a solid to a liquid?

- A Chemical change
- B Evaporation
- C Freezing
- D Physical change

Your answer

[1]

2 Which equipment is needed for distillation?

- A Condenser, funnel, thermometer
- B Condenser, round-bottomed flask, thermometer
- C Thermometer, beaker, pH probe
- D Thermometer, measuring cylinder, filter paper

Your answer

[1]

3 A carbon nanotube is  $1.4 \times 10^{-9}$  m wide. A human hair is  $1.4 \times 10^{-4}$  m wide.

How many times wider is the hair compared to the nanotube?

- A 100
- B 1000
- C 10 000
- D 100 000

Your answer

[1]

3

- 4 An element reacts with oxygen to form an **acidic oxide**.

Which area of the Periodic Table is the element from?

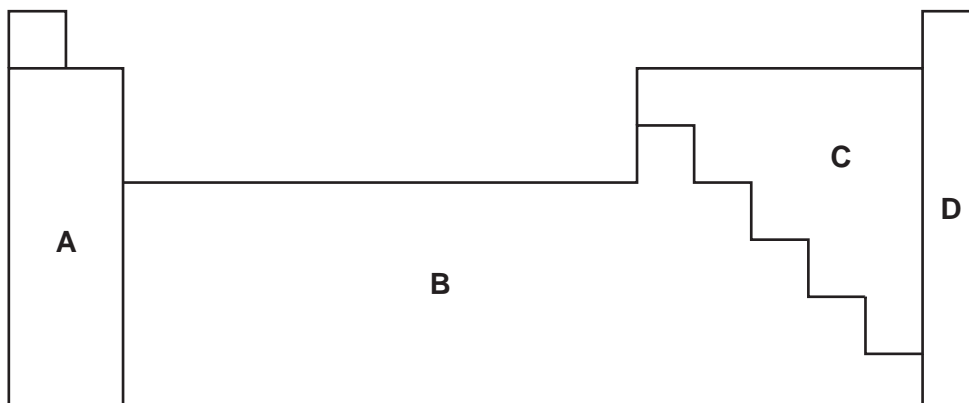

Your answer

[1]

- 5 The diagram shows a 3D space filling model of methane.

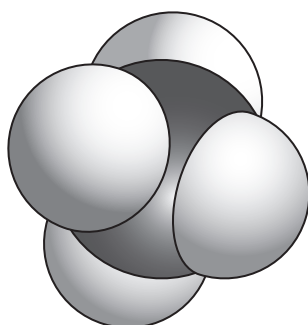

What are the limitations of showing methane as a 3D space filling model?

- A It does not show how close together the atoms are.
- B It does not show how many electrons are in a bond.
- C It does not show the relative size of the atoms.
- D It does not show the relative volume that the atoms take up.

Your answer

[1]

4

6 Which fraction is collected at the **top** of the fractional distillation column?

	Melting point range (°C)	Boiling point range (°C)
A	-70 – -60	20 – 25
B	-50 – -40	30 – 50
C	0 – 20	100 – 120
D	20 – 40	130 – 160

Your answer

[1]

7 How many moles are in 30g of nitrogen, N<sub>2</sub>?

Relative atomic mass ( $A_r$ ): N = 14.0

A 0.47 mol

B 0.93 mol

C 1.07 mol

D 2.14 mol

Your answer

[1]

8 Calcium phosphate contains the ions Ca<sup>2+</sup> and PO<sub>4</sub><sup>3-</sup>.

What is the formula for calcium phosphate?

A CaPO<sub>4</sub>

B Ca<sub>2</sub>PO<sub>4</sub>

C Ca<sub>2</sub>(PO<sub>4</sub>)<sub>3</sub>

D Ca<sub>3</sub>(PO<sub>4</sub>)<sub>2</sub>

Your answer

[1]

5

9 Which statement about an oxidising agent is correct?

- A It gains oxygen in a reaction.
- B It is oxidised in a reaction.
- C It is reduced in a reaction.
- D It loses electrons in a reaction.

Your answer

[1]

10 A solution of hydrochloric acid is pH 2. The acid solution is diluted, and the pH is now 3.

By what factor is the acid solution diluted?

- A 5
- B 10
- C 100
- D 1000

Your answer

[1]

11 Which row explains how the structure of graphene is different from the structure of graphite?

	Graphene	Graphite
A	3 covalent bonds to each carbon atom	4 covalent bonds to each carbon atom
B	covalent bonds in 3D	covalent bonds in one 2D plane
C	intermolecular forces	no intermolecular forces
D	one layer	many layers

Your answer

[1]

6

12 The empirical formula of a compound is  $\text{CH}_2\text{O}$ .

The relative formula mass of the compound is 180.0.

What is the **molecular formula** of the compound?

Relative atomic mass ( $A_r$ ): C = 12.0    H = 1.0    O = 16.0

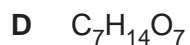
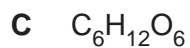
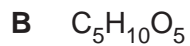
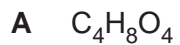

Your answer

[1]

13 Which diagram represents a **strong, dilute** acid?

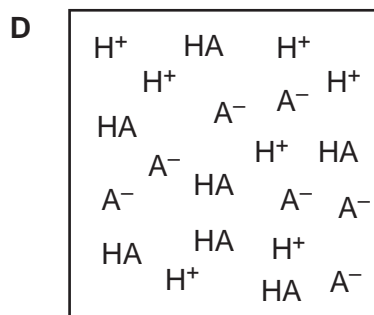
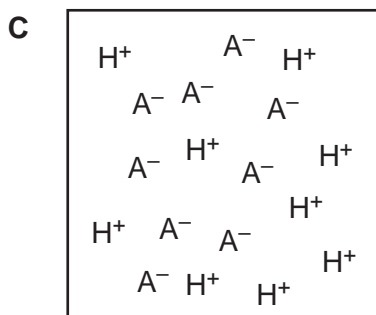
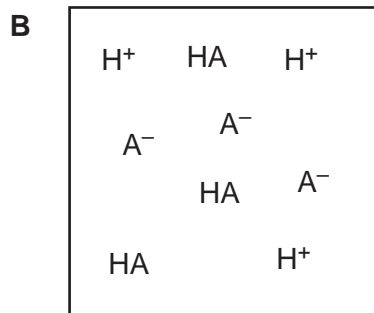
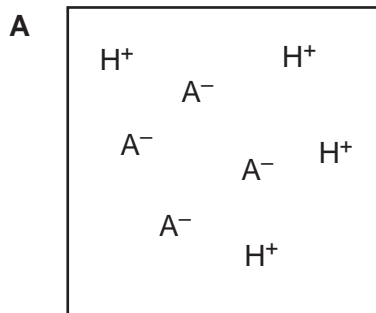

Your answer

[1]

7

14 What is the correct balanced equation for the combustion of hexane,  $C_6H_{14}$ ?

- A  $C_6H_{14} + 13O_2 \rightarrow 6CO_2 + 7H_2O$
- B  $C_6H_{14} + 6O_2 \rightarrow 6CO_2 + 7H_2O$
- C  $2C_6H_{14} + 19O_2 \rightarrow 12CO_2 + 14H_2O$
- D  $2C_6H_{14} + 26O_2 \rightarrow 12CO_2 + 14H_2O$

Your answer

[1]

15 A student investigates some samples using gas chromatography.

The student also measures the melting point of each sample.

Which results should the student expect from a **pure** sample?

	Gas chromatogram	Melting point (°C)
A	3 peaks	123–127
B	1 peak	123–127
C	2 peaks	125
D	1 peak	125

Your answer

[1]

8  
BLANK PAGE

PLEASE DO NOT WRITE ON THIS PAGE



## Section B

16 A scientist is studying acids and alkalis.

(a) Which statement about acids and alkalis is **correct**?

Tick (✓) **one** box.

A reaction between an acid and an alkali is neutralisation.

Acids form  $\text{OH}^-$  ions in solution.

Alkalis have a pH of less than 7.

Sodium hydroxide, NaOH, is an example of an acid.

[1]

(b) The scientist reacts sulfuric acid with insoluble magnesium carbonate,  $\text{MgCO}_3$ .

They repeat the experiment two more times.

The table shows their results.

	Experiment 1	Experiment 2	Experiment 3
Mass of magnesium sulfate, $\text{MgSO}_4$ , produced (g)	4.37	4.31	4.38
Mass of magnesium carbonate, $\text{MgCO}_3$ , remaining (g)	1.33	1.38	1.32

(i) Calculate the mean mass of magnesium sulfate,  $\text{MgSO}_4$ , made.

Give your answer to **3** significant figures.

Mean mass of magnesium sulfate = ..... g [3]

(ii) Complete the **balanced symbol** equation for the reaction.

Include state symbols.

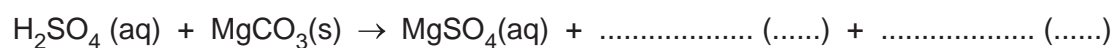

[2]

10

(iii) How does the scientist remove the unreacted solid magnesium carbonate,  $\text{MgCO}_3(\text{s})$ ?

..... [1]

(iv) How does the scientist obtain **pure dry** magnesium sulfate crystals from magnesium sulfate solution?

..... [1]

- 17 (a) A student does an experiment to find out the temperature change of the reaction between an acid and an alkali.

The diagram shows the student's experiment.

- (i) Label the equipment in the diagram.

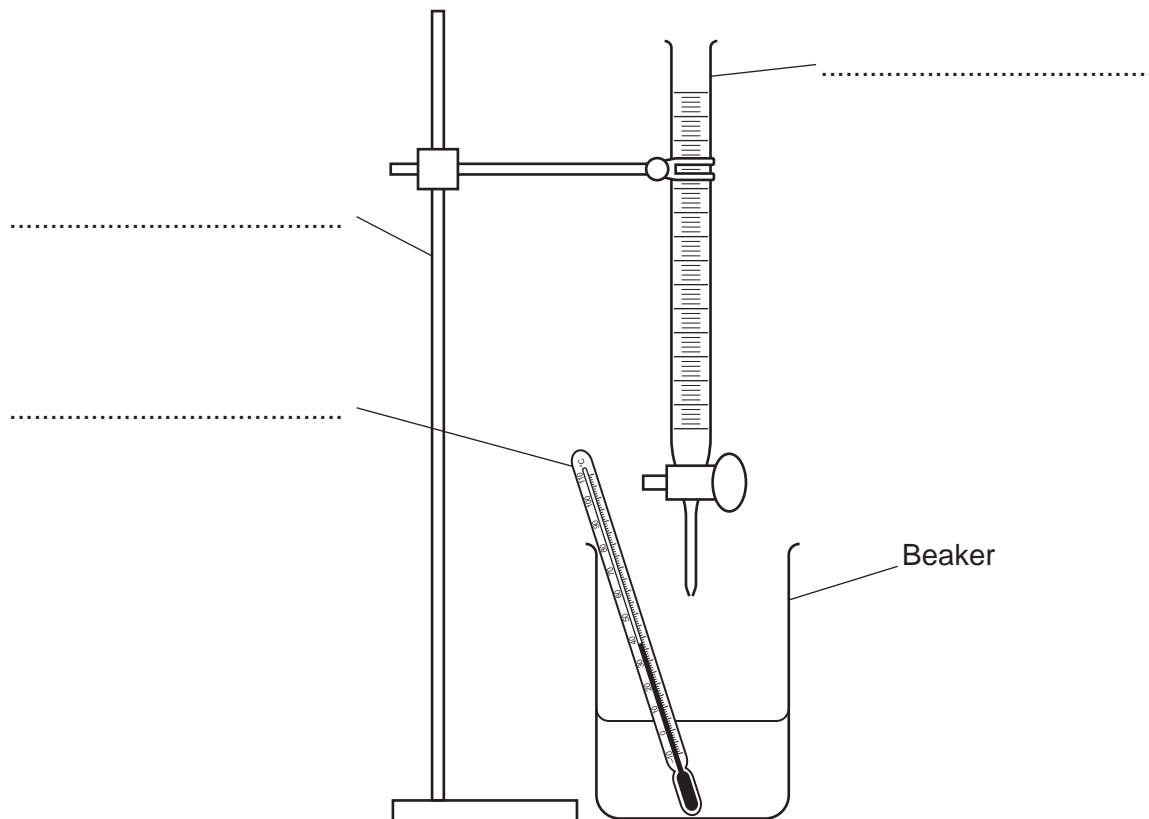

[3]

- (ii) Suggest **one** change the student can make so that the temperature change is measured more accurately. Use the diagram.

.....

..... [1]

## 12

(b) The student adds the acid,  $5 \text{ cm}^3$  at a time, to the alkali in the beaker.

The student records the temperature of the solution after each addition of acid.

The table shows their results.

Volume of acid ( $\text{cm}^3$ )	Temperature ( $^{\circ}\text{C}$ )
0	18
5	20
10	23
15	26
20	27
25	26
30	24

13

- (i) Plot the results from the table on the grid.

Temperature  
(°C)

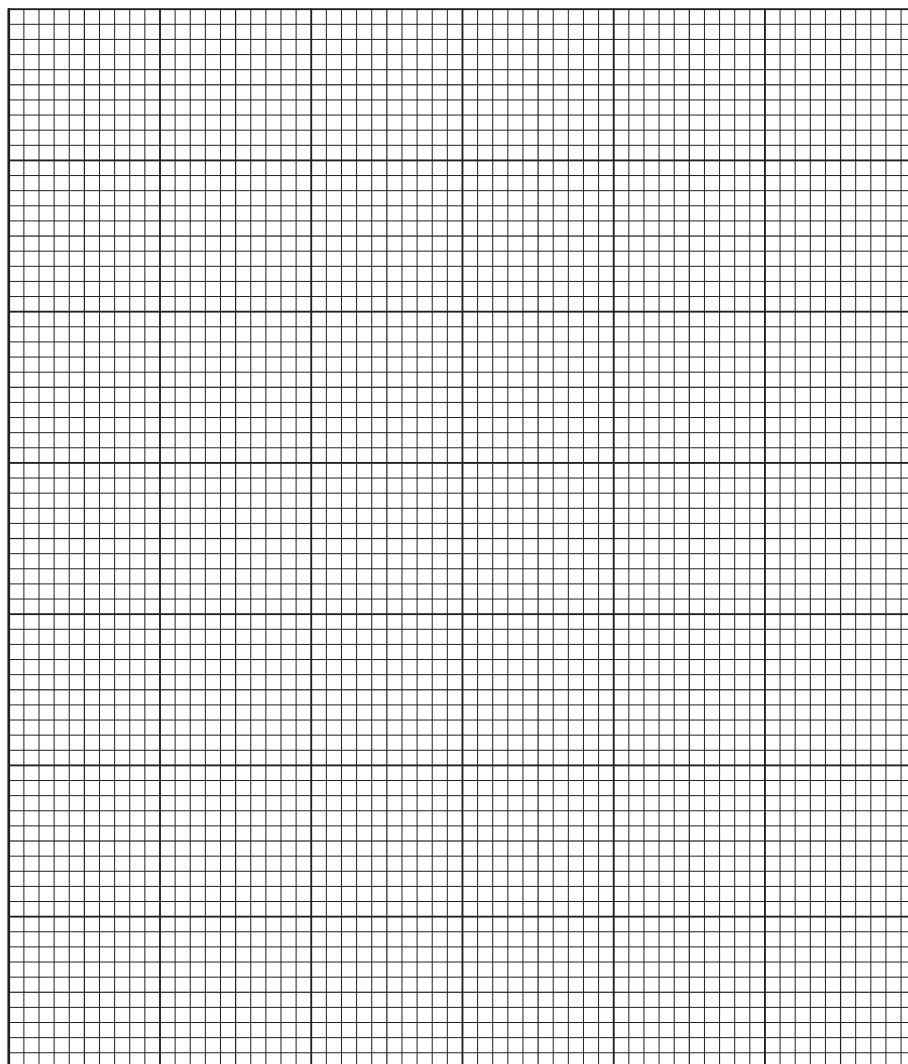

Volume of acid (cm<sup>3</sup>)

[2]

- (ii) Describe what happens to the temperature measured as the acid is added.

.....  
.....  
..... [2]

- (iii) The reaction is exothermic.

Explain how you can tell this from the student's results.

.....  
..... [1]

14

(c) The activation energy for the student's reaction is 132 kJ/mol.

Complete the sentence to state the meaning of activation energy.

Activation energy is the minimum .....

..... [1]

15

18 (a) The model of the atom has developed over time.

Describe the experiment **and** results that Rutherford, Geiger, and Marsden used to determine that an atom has a nucleus.

.....

.....

.....

.....

.....

..... [3]

(b) Which statements about atoms are **correct**?

Tick (✓) **two** boxes.

A proton has a positive charge and a relative mass of 1.

An atomic radius is approximately  $1 \times 10^{-12}$  m.

An electron has a negative charge and a relative mass of 1.

Most of the mass of the atom is in the nucleus.

The radius of an atom is much smaller than the radius of a nucleus.

[2]

(c) Complete the dot and cross diagram to show the bonding in carbon dioxide, CO<sub>2</sub>.

You only need to show the outer shell electrons.

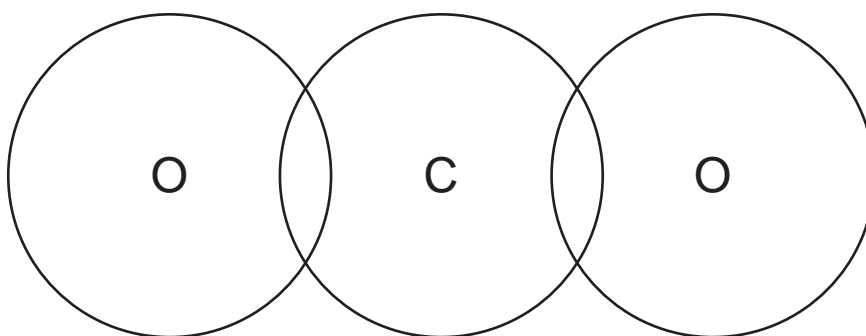

[2]

16

- (d) (i) At  $-78^{\circ}\text{C}$ , and 0.1 MPa pressure, carbon dioxide changes state from a solid to a gas.

Changing state from a solid to a gas is called **subliming**.

Describe what happens to the **movement** and **arrangement** of the particles when a solid turns into a gas. Use the particle model.

.....

.....

.....

.....

..... [3]

- (ii) Carbon dioxide can be a liquid at different pressures and temperatures.

Pressure (MPa)	Melting point ( $^{\circ}\text{C}$ )	Boiling point ( $^{\circ}\text{C}$ )	Sublimation point ( $^{\circ}\text{C}$ )
0.1			-78
1.0	-56	-40	

State a temperature and a pressure at which carbon dioxide is a **liquid**.

Explain your answer.

Temperature .....  $^{\circ}\text{C}$  Pressure ..... MPa

Reason .....

.....

..... [3]





18

(b) Another scientist investigates the electrolysis of lead bromide.

The diagram shows their experiment.

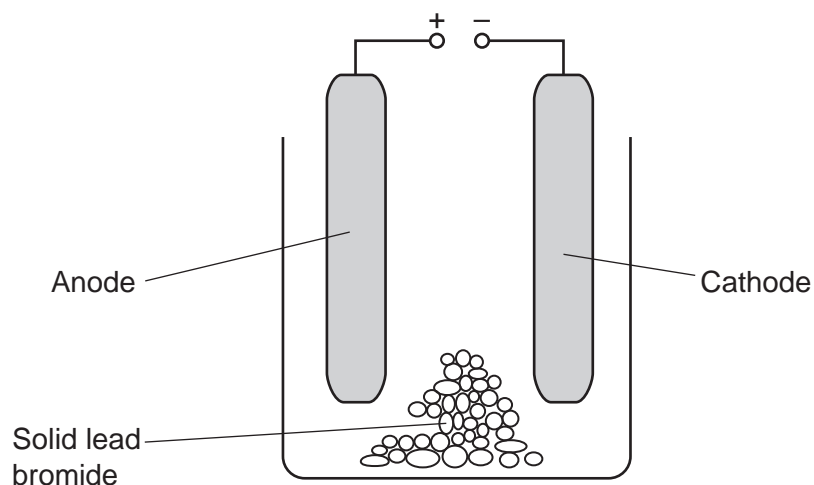

The experiment does **not** make any lead.

State **two** changes the scientist should make so that lead is made.

1 .....

.....

2 .....

.....

[2]

(c) Complete the **balanced half** equation for the production of bromine from bromide ions.



[2]

19

20 (a) A scientist has a sample of seawater. The sample contains sand, water and salt.

The scientist wants to collect **pure** samples of:

- sand
- water
- salt.

Describe a method the scientist could use to separate and collect the sand, water and salt.

You can include labelled diagrams in your answer.

.....

.....

.....

.....

.....

.....

.....

.....

.....

..... [4]

(b) The salt collected is sodium chloride.

Complete the ball and stick model by labelling the sodium ions and the chloride ions.

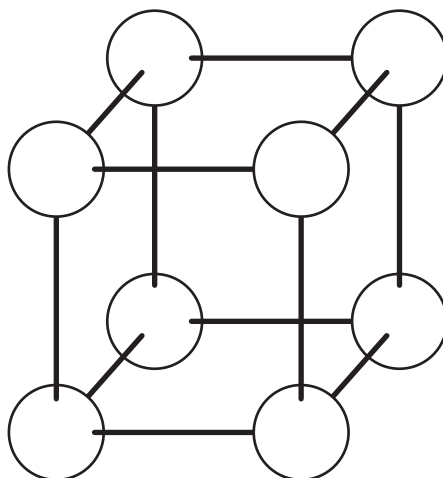

[2]

(c) Seawater can contain isotopes of sulfur.

(i) Draw **three** lines to connect each **isotope** with its correct **description**.

Isotope	Description
16 <b>S</b> 32	This isotope contains 17 neutrons.
16 <b>S</b> 33	This isotope has a full outer shell of electrons.
16 <b>S</b> 34	This isotope has more protons than neutrons.
	This isotope has the highest mass number.
	This isotope has the same number of neutrons and protons.

[2]

21

- (ii) Some of this sulfur in seawater is in the form of magnesium sulfate,  $\text{MgSO}_4$ .

What is the relative formula mass of a sample of magnesium sulfate,  $\text{MgSO}_4$ , where all of the sulfur atoms are the isotope sulfur-33?

Sulfur-33 is

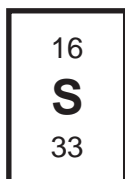

Relative atomic mass ( $A_r$ ): O = 16.0      Mg = 24.3

Relative formula mass = ..... [2]

- (iii) A scientist wants to separate magnesium sulfate from other compounds using thin layer chromatography.

The spot does **not** move from the start line on the chromatogram.

State what the scientist should change so that magnesium sulfate is separated from the other compounds.

..... [1]

- (iv) Explain why magnesium sulfate has a high melting point.

.....  
 .....  
 ..... [2]

21 Table 21.1 shows information about four different substances.

Table 21.1

Substance	Melting point (°C)	Appearance	Electrical conductor?
1	1085	shiny solid	yes
2	770	white crystals	yes when dissolved in water
3	120	flexible solid	no
4	78	white crystals	no

(a) Which of the substances is a polymer?

Explain your answer.

Substance .....

Reason .....

.....  
 .....

[3]

(b) Fig. 21.1 shows two different polymer structures.

Fig. 21.1

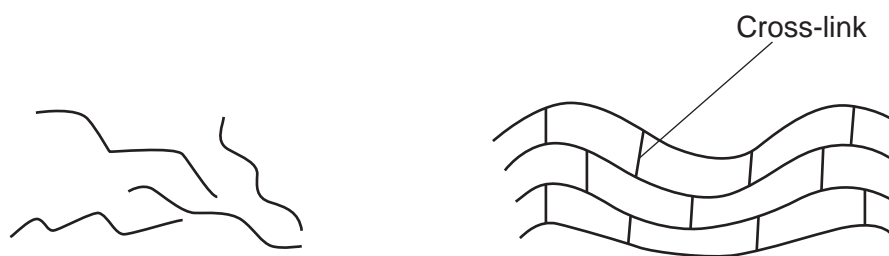

Explain why polymers without cross-links can stretch more than polymers with cross-links.

.....  
 .....

[2]

(c) Fig. 21.2 shows an electrical cable.

Fig. 21.2

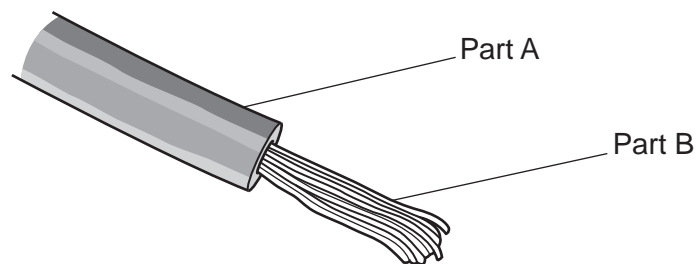

Which substance from **Table 21.1** would be best to use to make each part of the electrical cable?

Explain your answers.

Part A .....

Reason .....

Part B .....

Reason .....

[3]

## 24

22 Magnesium nitrate decomposes when heated to form magnesium oxide.



(a) (i) Calculate the **mass** of oxygen made when 0.45 moles of magnesium nitrate decomposes.

Relative atomic mass ( $A_r$ ): O = 16.0.

Mass of oxygen = ..... g [3]

(ii) Calculate how many **molecules** of nitrogen dioxide,  $\text{NO}_2$ , are produced from 0.45 moles of magnesium nitrate.

The Avogadro constant is  $6.02 \times 10^{23}$ .

Give your answer to **3** significant figures.

Number of molecules of  $\text{NO}_2$  = ..... [3]



25

(b) The decomposition of magnesium nitrate is an **endothermic** reaction.

Complete the reaction profile for an endothermic reaction.

Include the labels:

- products
- activation energy
- energy change of reaction.

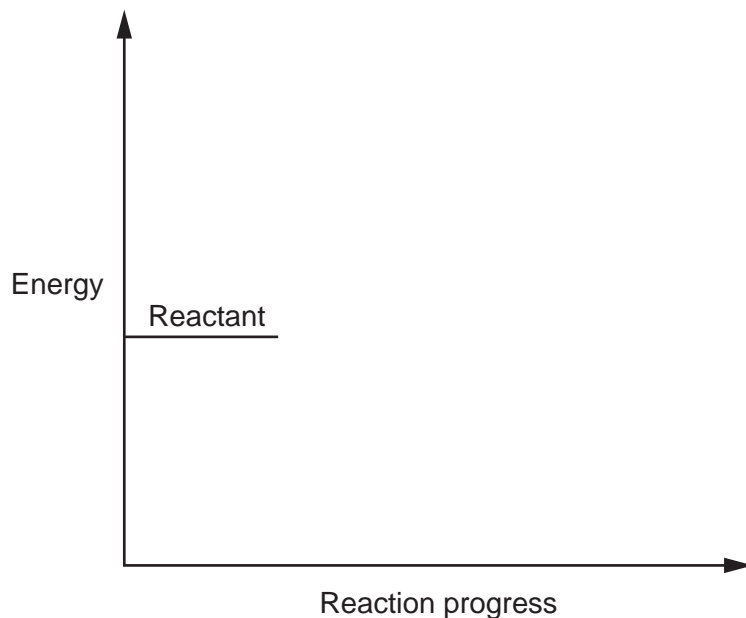

[4]

(c) Magnesium nitrate is an ionic compound.

(i) Explain why magnesium forms  $\text{Mg}^{2+}$  ions.

.....  
 ..... [1]

(ii) A solution containing magnesium ions reacts with a solution containing hydroxide ions.

Solid magnesium hydroxide is made.

Write the **balanced ionic** equation for this reaction.

..... [2]

**END OF QUESTION PAPER**

**ADDITIONAL ANSWER SPACE**

If additional space is required, you should use the following lined page(s). The question number(s) must be clearly shown in the margin(s).

This section of the page is a large, empty area of lined paper. It features a vertical solid line on the left side, creating a margin. The rest of the page is filled with horizontal dotted lines, providing space for writing answers. The lines are evenly spaced and extend across the width of the page.



A large area of the page is filled with horizontal dotted lines, providing a space for writing answers. A solid vertical line runs down the left side of this area, creating a margin.

---

# OCR

Oxford Cambridge and RSA

## Copyright Information

OCR is committed to seeking permission to reproduce all third-party content that it uses in its assessment materials. OCR has attempted to identify and contact all copyright holders whose work is used in this paper. To avoid the issue of disclosure of answer-related information to candidates, all copyright acknowledgements are reproduced in the OCR Copyright Acknowledgements Booklet. This is produced for each series of examinations and is freely available to download from our public website ([www.ocr.org.uk](http://www.ocr.org.uk)) after the live examination series.

If OCR has unwittingly failed to correctly acknowledge or clear any third-party content in this assessment material, OCR will be happy to correct its mistake at the earliest possible opportunity.

For queries or further information please contact The OCR Copyright Team, The Triangle Building, Shaftesbury Road, Cambridge CB2 8EA.

OCR is part of Cambridge University Press & Assessment, which is itself a department of the University of Cambridge.